

5 Watts

- Compact Size
- Single Outputs from 3.3 to 48 V
- PCB Mount
- Encapsulated & Open Frame
- Class II
- <0.3 W No Load Input Power
- Peak Load Capability
- Low Cost
- 3 Year Warranty

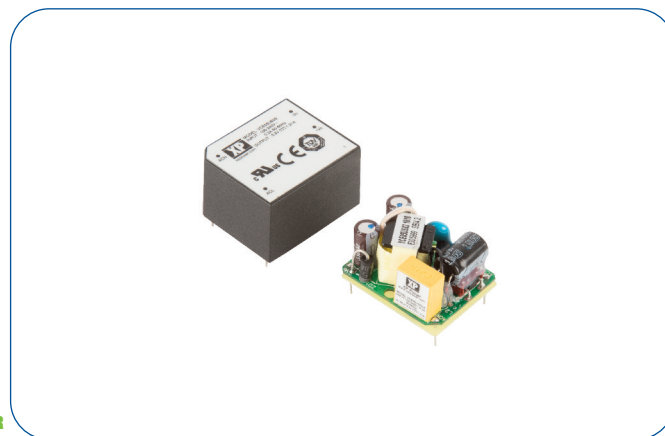

Dimensions:

VCE05:
1.30 x 1.10 x 0.75" (33.02 x 27.94 x 19.05 mm)
VCE05-P:
1.20 x 1.00 x 0.705" (30.8 x 25.4 x 17.9 mm)

The VCE05 is a series of open frame and encapsulated AC-DC single output power supplies designed for low cost ITE and Industrial applications. The series provides two mechanical options including open frame and encapsulated PCB mount. With approvals to world-wide safety standards, compliance with class B for conducted and radiated emissions and a 130%, 30s peak load capability, these class II isolation parts benefit system designers with easy integration into a wide range of applications.

Models & Ratings

Output Power	Output Voltage	Output Current		Model Number ⁽²⁾
		Nominal	Peak ⁽¹⁾	
5 W	3.3 VDC	1210 mA	1573 mA	VCE05US03
5 W	5.0 VDC	1000 mA	1300 mA	VCE05US05
5 W	9.0 VDC	550 mA	722 mA	VCE05US09
5 W	12.0 VDC	410 mA	541 mA	VCE05US12
5 W	15.0 VDC	330 mA	433 mA	VCE05US15
5 W	24.0 VDC	210 mA	270 mA	VCE05US24
5 W	48.0 VDC	100 mA	135 mA	VCE05US48

Notes

1. Peak load lasting <30 s with a maximum duty cycle of 10%, average output power not to exceed nominal.
2. For Open Frame version add suffix -P to model number, e.g. VCE05US12-P.

Summary

Characteristic	Minimum	Typical	Maximum	Units	Notes & Conditions
Input Voltage Range	85		264	VAC	Derate from 100% at 90 VAC to 90% at 85 VAC
No Load Input Power			0.3	W	
Efficiency		78		%	Model dependant
Operating Temperature	-25		+70	°C	Derate linearly from 100% at +50 °C to 50% at +70 °C
EMC	EN55022 Level B Conducted & Radiated, EN61000-3-2, EN61000-3-3, EN60601-1-2				
Safety Approvals	EN60950, UL60950, IEC60950				

Input

Characteristic	Minimum	Typical	Maximum	Units	Notes & Conditions
Input Voltage Range	85		264	VAC	
Input Frequency	47		63	Hz	
Input Current - Full Load		0.10/0.06		A rms	At 115/230 VAC
No Load Input Power			0.3	W	
Inrush Current			40	A	At 230 VAC
Earth Leakage Current					Class II construction no earth
Input Protection	Internal T1.0 A/250 VAC fuse fitted in line				

Output

Characteristic	Minimum	Typical	Maximum	Units	Notes & Conditions
Output Voltage	3.3		48	VDC	
Initial Set Accuracy			3/2	%	3% for 03 & 05 models, 2% for others at 50% load
Minimum Load	0			A	No minimum load required
Line Regulation			±1.0	%	
Load Regulation			3/2	%	3% for 03 & 05 models, 2% for others from 10% to 100% load
Start Up Delay			2	s	
Start Up Rise Time			14	ms	
Hold Up Time	6	9		ms	at full load and 115 VAC
Transient Response			4	%	Deviation, recovery within 1% in less than 500 µs for a 25% load change
Ripple & Noise			180	mV pk-pk	3.3-5V, 20 MHz bandwidth
			1	% pk-pk	9V to 48V models, 20 MHz bandwidth
Overvoltage Protection	115		140	% Vnom	Recycle input to reset
Overload Protection	110		180	%	
Short Circuit Protection					Trip & Restart (hiccup mode)
Temperature Coefficient			0.05	%/°C	

General

Characteristic	Minimum	Typical	Maximum	Units	Notes & Conditions
Efficiency		78		%	Model Dependant
Isolation: Input to Output	3000			VAC	
Switching Frequency		40		kHz	
Power Density			5.9	W/in ³	
Mean Time Between Failure		>400		kHrs	MIL-HDBK-217F, +25 °C GB
Weight		0.03 (14)		lb (g)	Open frame versions (-P)
		0.053 (24)		lb (g)	Encapsulated version

Efficiency Graphs

VCE05US12

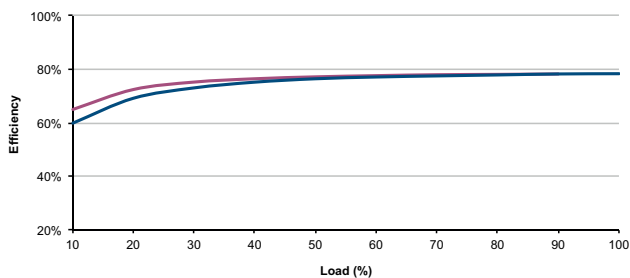

VCE05US24

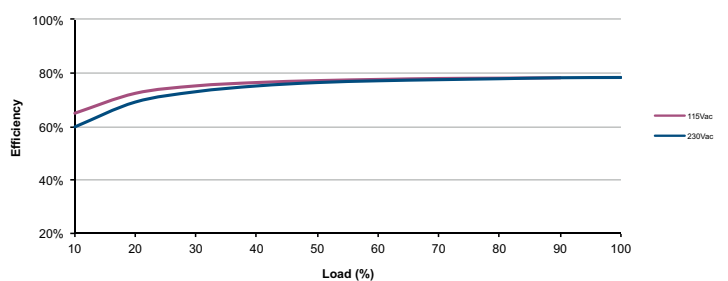

Environmental

Characteristic	Minimum	Typical	Maximum	Units	Notes & Conditions
Operating Temperature	-25		+70	°C	Derate linearly from 100% at +50 °C to 50% at +70 °C
Storage Temperature	-40		+85	°C	
Cooling					Convection-cooled
Humidity			95	%RH	Non-condensing
Operating Altitude			3048	m	
Shock	IEC68-2-27, 30 g, 11 ms half sine, 3 times in each of 6 axes				
Vibration	IEC68-2-6, 2 g, 10 Hz to 500 kHz, 10 mins/cycle, 60 mins each cycle				

EMC: Emissions

Phenomenon	Standard	Test Level	Criteria	Notes & Conditions
Conducted	EN55022	Class B		
Radiated	EN55022	Class B		
Harmonic Current	EN61000-3-2			Class A
Voltage Flicker	EN61000-3-3			

EMC: Immunity

Phenomenon	Standard	Test Level	Criteria	Notes & Conditions
ESD	EN61000-4-2	±6kV contact, ±8kV air discharge	A	
Radiated	EN61000-4-3	10 V/m	A	
EFT	EN61000-4-4	3	A	
Surge	EN61000-4-5	2	A	Line to Line
Conducted	EN61000-4-6	10 Vrms	A	
Magnetic Fields	EN61000-4-8	30 A/m	A	
Dips and Interruptions	EN61000-4-11 (115 VAC)	70% U _r (80.5 VAC) for 100 ms	A	A at High Line, B at Low Line
		40% U _r (46 VAC) for 200 ms	B	
		<5% U _r (0 VAC) for 10 ms	A	
		<5% U _r (0 VAC) for 5000 ms	B	
	EN61000-4-11 (230 VAC)	70% U _r (161 VAC) for 100 ms	A	A at High Line, B at Low Line
		40% U _r (92 VAC) for 200 ms	A	
		<5% U _r (0 VAC) for 10 ms	A	
		<5% U _r (0 VAC) for 5000 ms	B	

Safety Approvals

Safety Agency	Safety Standard	Notes & Conditions
CB Report	IEC60950	
UL	UL60950-1 & CSA C22.2, No.60950-1:08	
TUV	EN60950-1	

Mechanical Details

Encapsulated

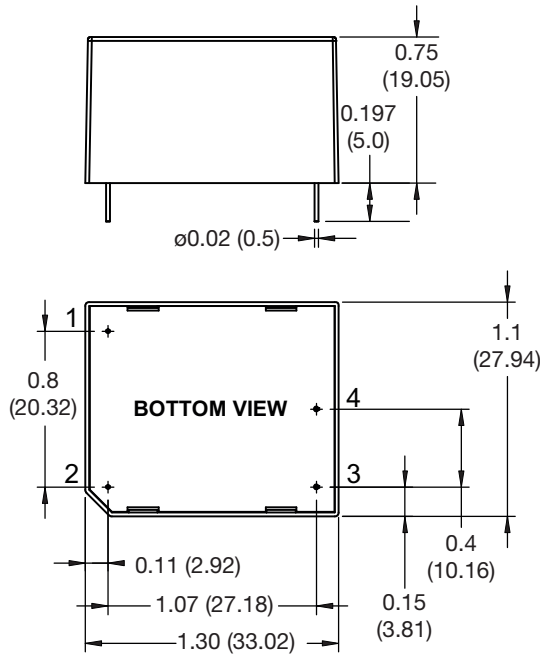

Pin Connections	
Pin	Single
1	ACN
2	ACL
3	-Vout
4	+Vout

Open Frame (-P)

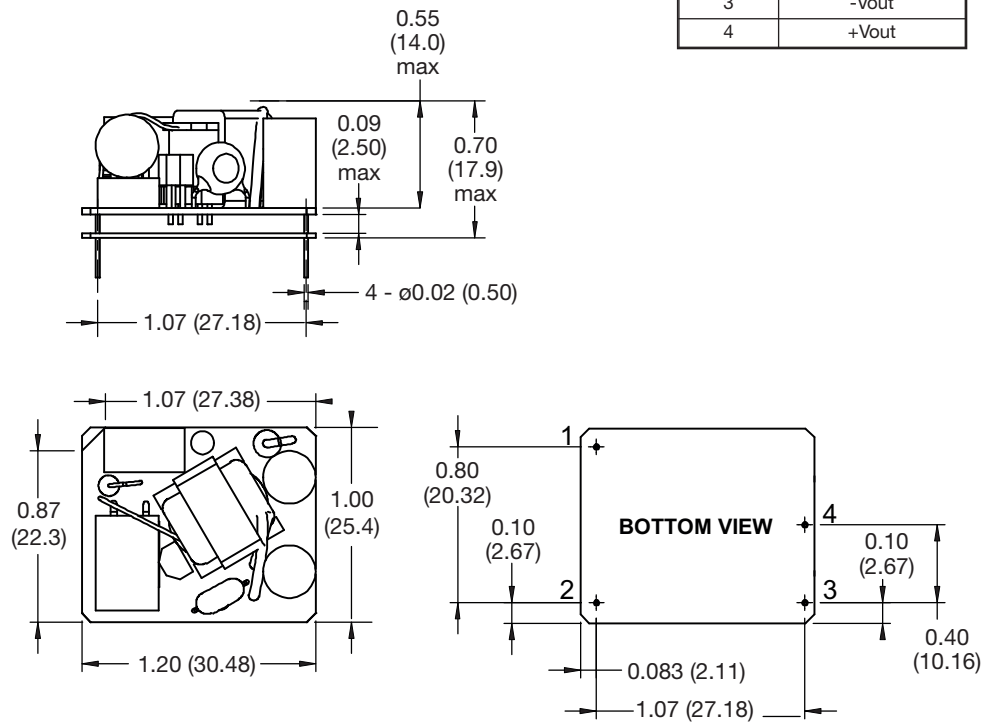

Notes

1. Dimensions in inches (mm).
2. Weight: Open frame versions (-P): 0.03 lbs (14 g)
Encapsulated: 0.053 lbs (24 g)

3. Tolerances: x.xx = ± 0.02 (x.x = ± 0.5)
x.xxx = ± 0.01 (x.xx = ± 0.25)